

ASSEMBLY INSTRUCTIONS

STEP 1

1. WITH THE HELP OF SOMEONE ELSE TURN THE TABLE AND PLACE THE TOP ON A FLAT SURFACE ALING THE LEGS HOLES WITH THE APRON HOLES.

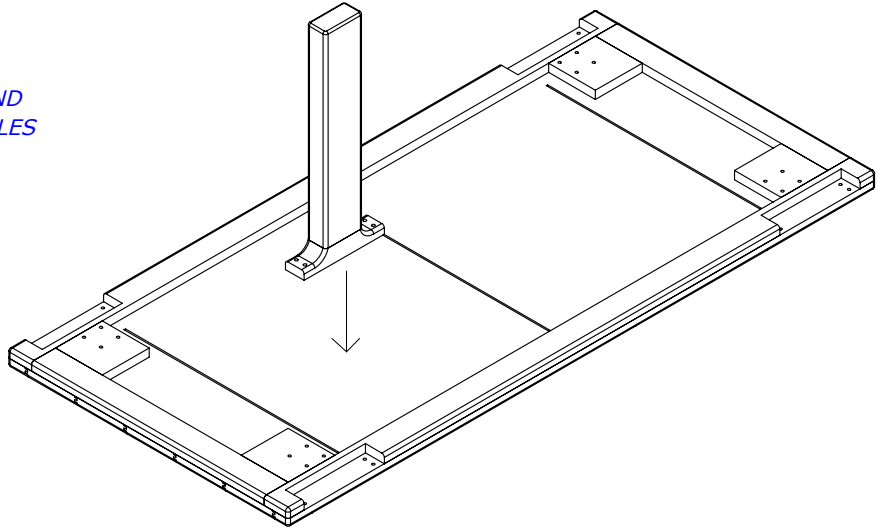

STEP 2

2. ONCE THE HOLES HAVE BEEN MATCHED PLACE THE UNION SCREWS 1/4" X 1-3/4" AS SHOWN IN FIGURE "A" AND TIGHTEN THE SCREWS.
3. PLACE AND REPEAT WITH THE OTHER LEGS

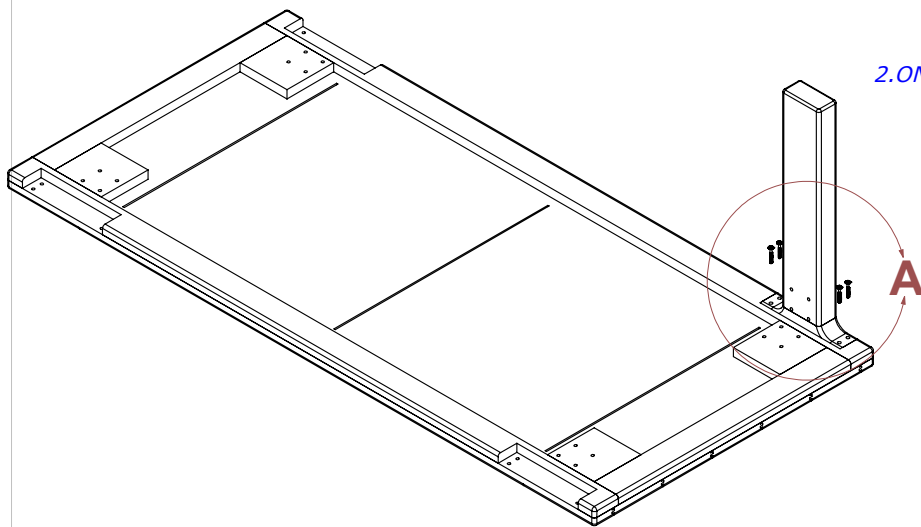

UNION SCREW 1/4 X 1-3/4"

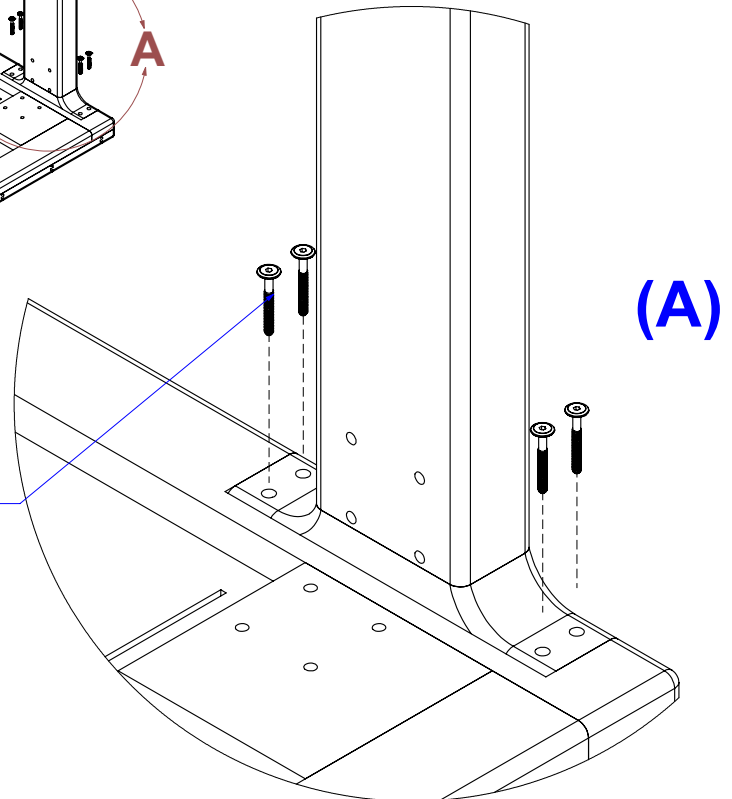

| DESCRIPTION | # |
|---------------------------|----|
| UNION SCREW 1/4" X 1-3/4" | 16 |
| UNION SCREW 1/4" X 3/4" | 32 |
| ALLEN KEY 5/32" | 1 |

I-TBL-E026

ASSEMBLY INSTRUCTIONS (B)

STEP 3

4. ONCE THE LEGS ARE IN THEIR PLACE, PLACE THE METAL BRACKET AS SHOWN IN FIG. "B" ONCE THE HOLES HAVE BEEN MATCHED PLACE THE UNION SCREWS 1/4" X 3/4" AS SHOWN IN FIGURE "C" AND TIGHTEN THE SCREWS.

5. ONCE THE SCREWS HAVE BEEN TIGHTENED, WITH THE HELP OF SOMEONE ELSE GET THE TABLE UP RIGHT AND PLACE IT IN THE DESIRED LOCATION

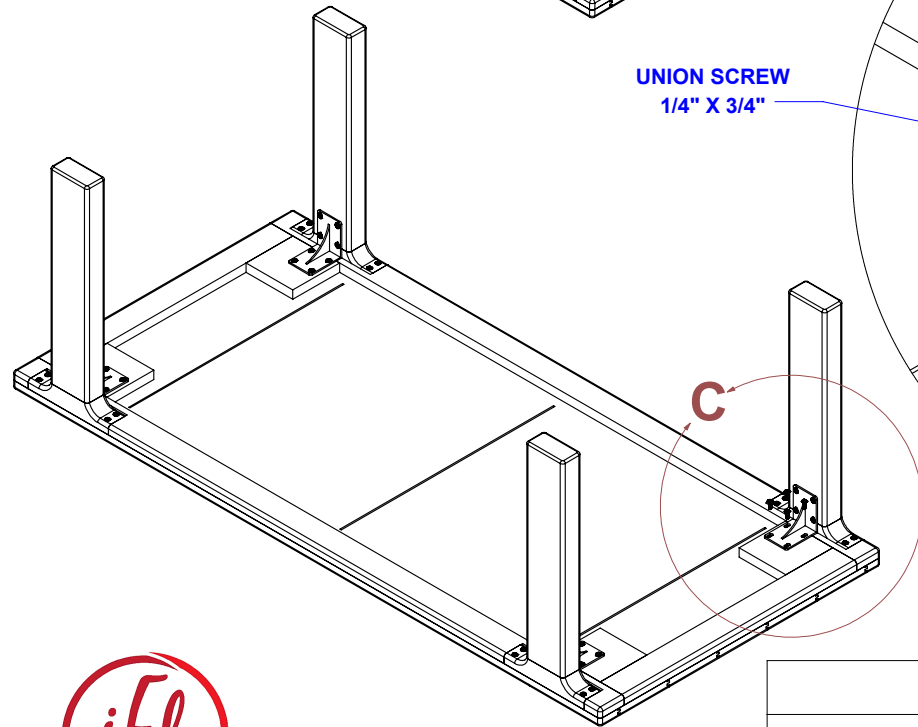
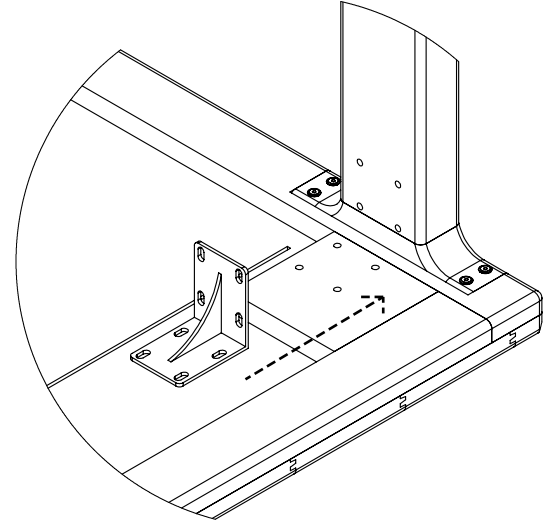
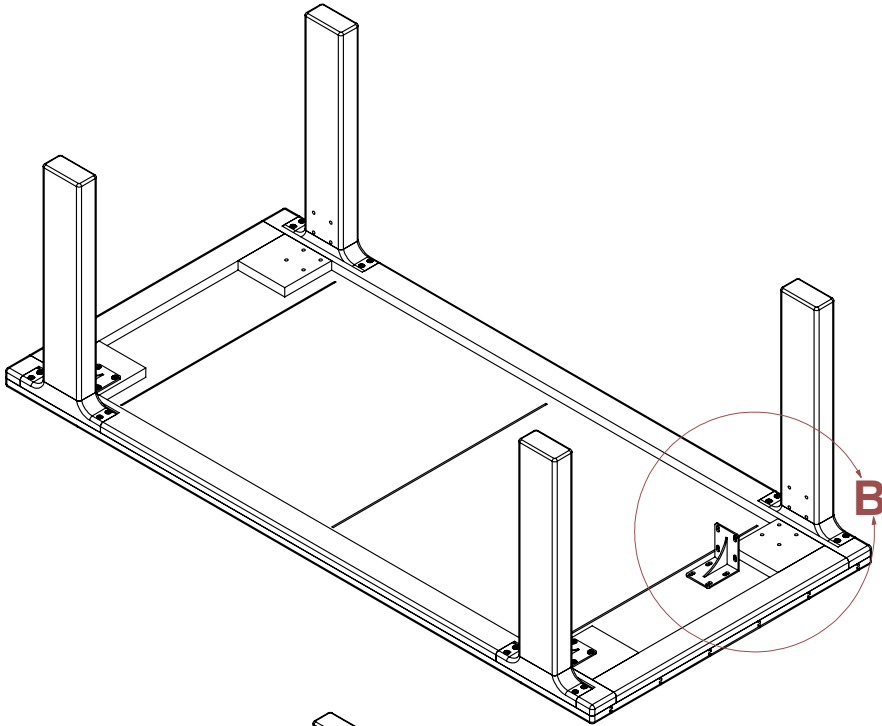

UNION SCREW
1/4" X 3/4"

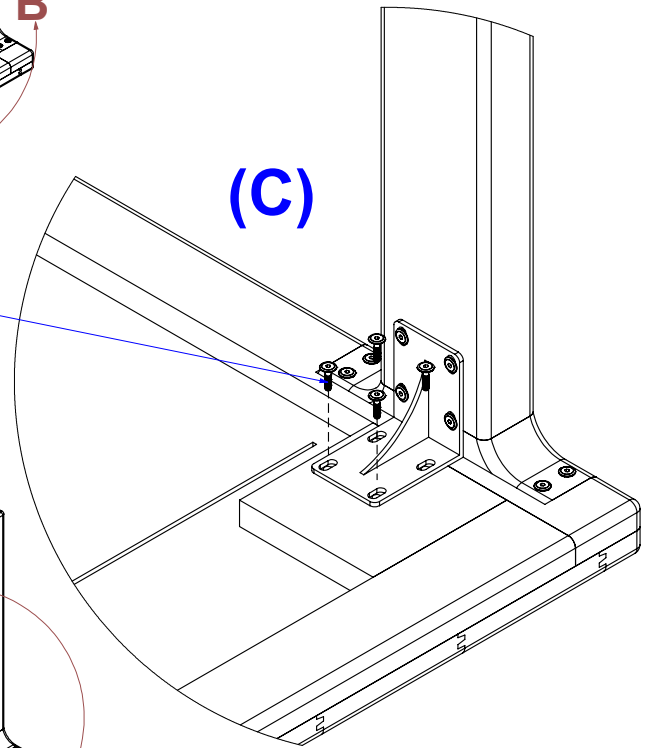

(C)



| DESCRIPTION | # |
|---------------------------|----|
| UNION SCREW 1/4" X 1-3/4" | 16 |
| UNION SCREW 1/4" X 3/4" | 32 |
| ALLEN KEY 5/32" | 1 |

I-TBL-E026