

STEP 1

WITH THE HELP OF SOMEONE WE PUT THE COVER UPSIDE DOWN. UPSIDE DOWN, PAY ATTENTION TO PLACE THE SCREWS SCREWS MENTIONED IN THE TABLE AND FIGURE A

A

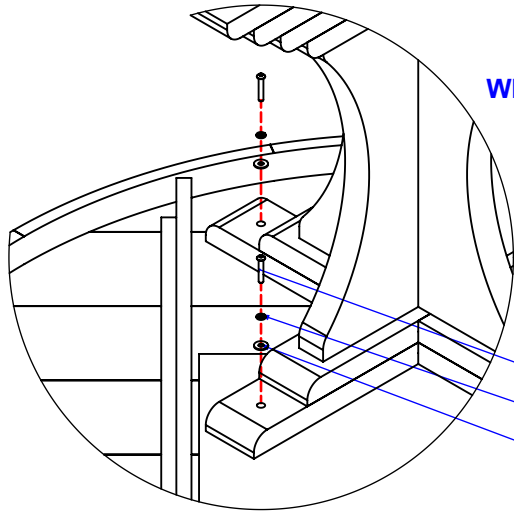

- BUTTON SOCKET SCREW 5/16 X 1 1/2"
- SPLIT LOCK WASHER 5/16
- FLAT WASHER 5/16 X 1"

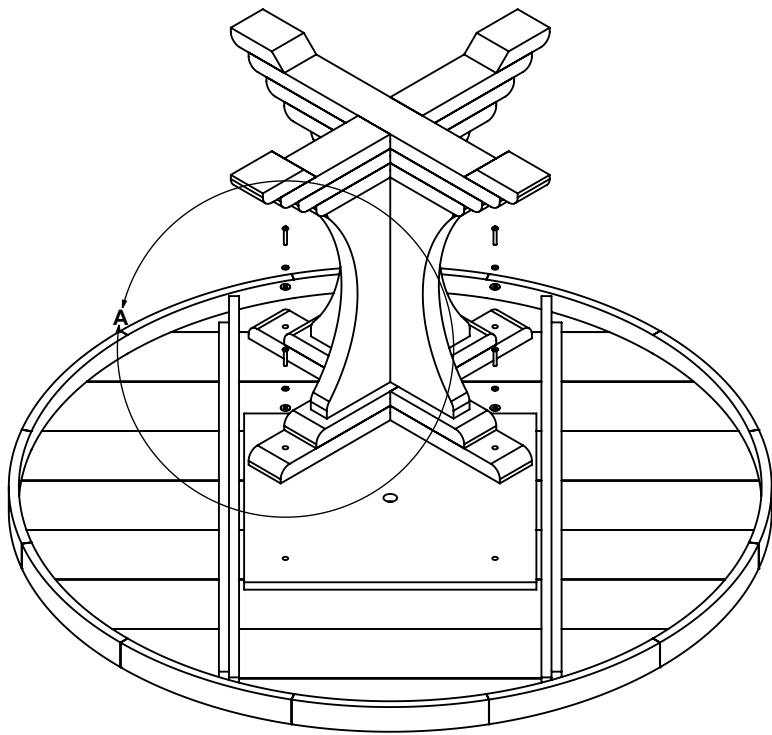

STEP 2

THEN WITH THE HELP OF SOMEONE WE TURN THE DINING ROOM AND PLACE IT IN THE DESIRED LOCATION

DESCRIPTION	#
BUTTON COCKET SCREW 5/16 X 1 1/2"	4
SPLIT LOCK WASHER 5/16	4
FLAT WASHER 5/16 X 1"	4
ALLEN KEY 3/16	1



INTERNATIONAL
FURNITURE DIRECT, LLC

ASSEMBLING
INSTRUCTIONS

I-TBL-E022

ITEM	DESCRIPTION	#
1TOR005	TORNILLO ALLEN DE 5/16 X 1 1/2"	4
1RON003	RONDANA PLANA DE 5/16 X 1"	4
1RON011	RONDANA DE PRESION DE 5/16	4
1HER251	ALLEN KEY 3/16	1



INTERNATIONAL
FURNITURE DIRECT, LLC

ASSEMBLING
INSTRUCTIONS

I-TBL-E022: