

1.-WITH SOMEONE'S HELP, FLIP THE COVER OVER TO TAKE THE TO TAKE THE 2 BASE PIECES.

2. CENTER AND MATCH THE BASE AND COVER HOLES, AS SHOWN IN FIGURE A, MAKE SURE THAT THE POSITION OF THE TERMINAL BLOCK IS AS SHOWN IN FIGURE C.

3. WHEN THE BASES ARE ALIGNED, PLACE THE SCREWS, SPLIT LOCK WASHER AND FLAT WASHER, TO SCREW IN WITH THE 5/16 ALLEN WRENCH. AS SHOWN IN FIGURE B

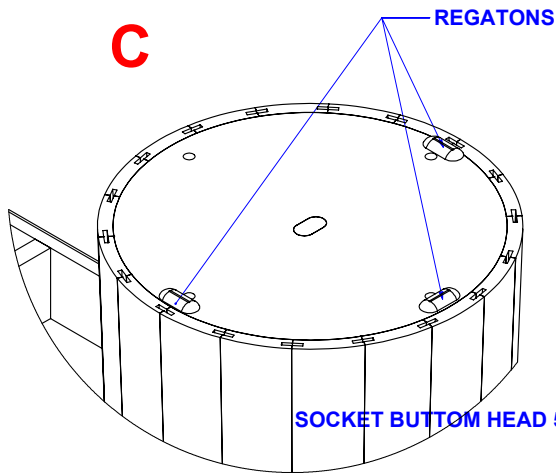
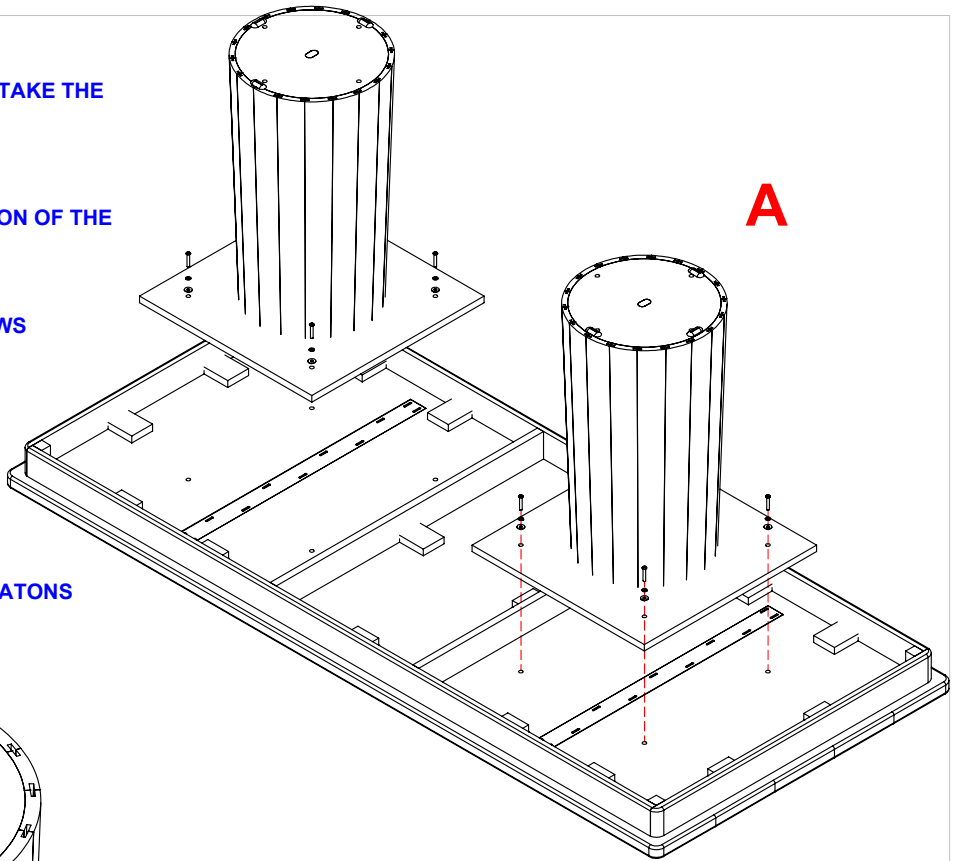

SOCKET BUTTOM HEAD 5/16 X 1- 1/2"

SPLIT LOCK WASHER 5/16

FLAT WASHER 5/16

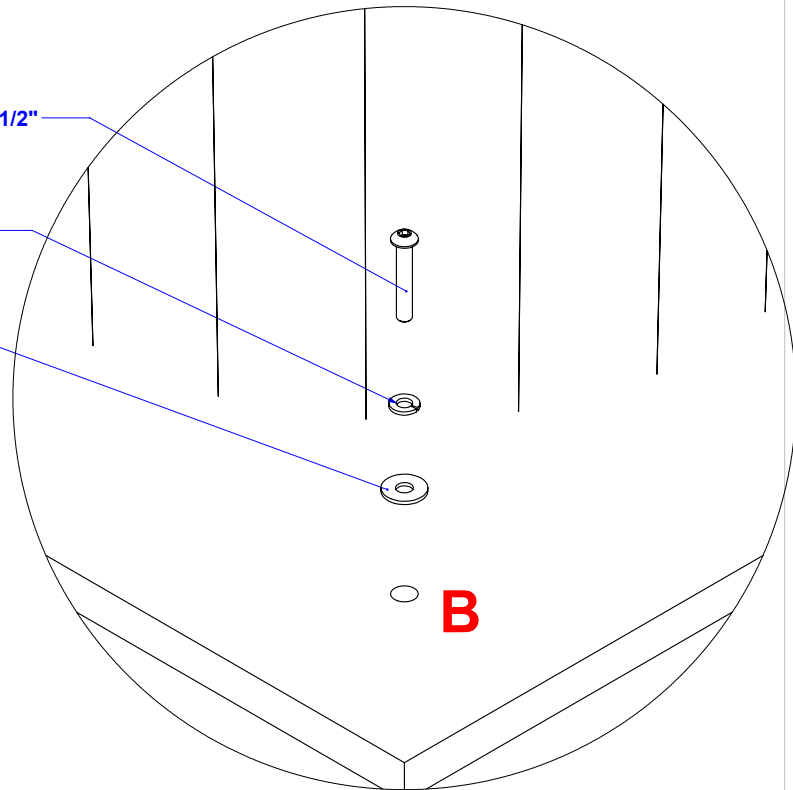

REGATONS

REGATONS

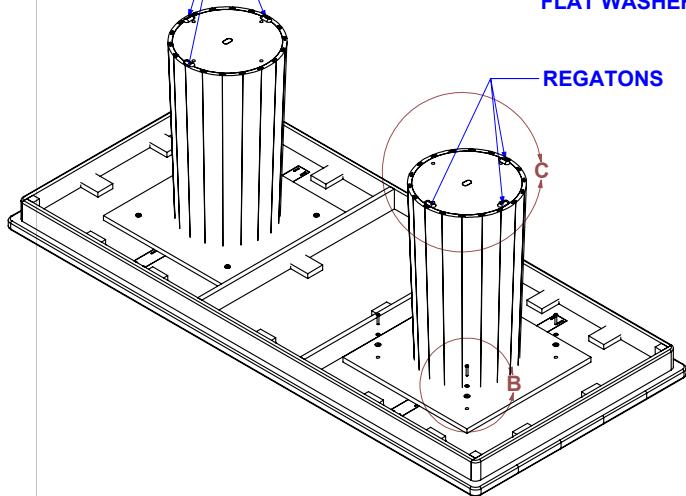

DESCRIPTION	#
SOCKET BUTTOM HEAD 5/16 X 1-1/2"	8
FLAT WASHER 5/16	8
LOCK WASHER 5/16	8
ALLEN KEY 3/16	1

ifd

INTERNATIONAL
FURNITURE DIRECT, LLC

CODIGO:

I-TBL-E015

DINING

ITEM	DESCRIPTION	#PZ
1RON003	RONDANA PLANA 5/16 X 1"	8
1RON011	RONDANA DE PRESION 5/16	8
1TOR005	TORNILLO ALLEN CABEZA BOLA 5/16 X 1-1/2"	8
1HER251	LLAVE ALLEN 3/16	1



INTERNATIONAL
FURNITURE DIRECT, LLC

CODIGO:

I-TBL-E015

DINING