

THE IMAGES ARE FOR REFERENCE ONLY.

STEP 1

WITH THE HELP OF SOMEONE ELSE ALING THE RAILS HOLES WITH THE HEADBOARD HOLES

STEP 2

ONCE ITS PLACED INSERT THE SCREWS AND WASHERS AS SHOWN IN FIG. A

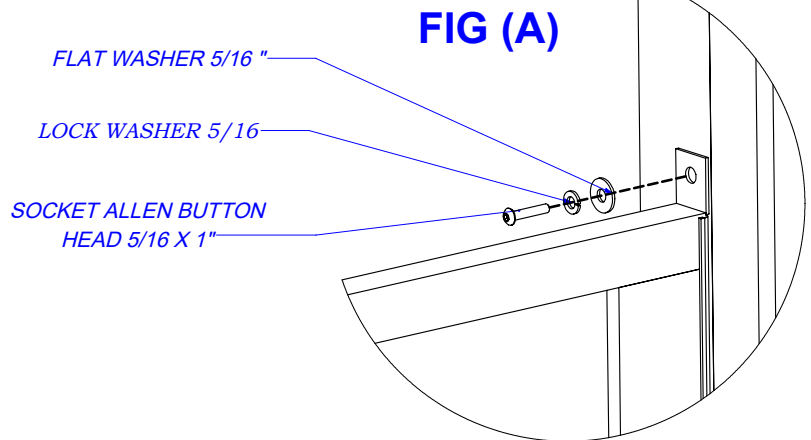
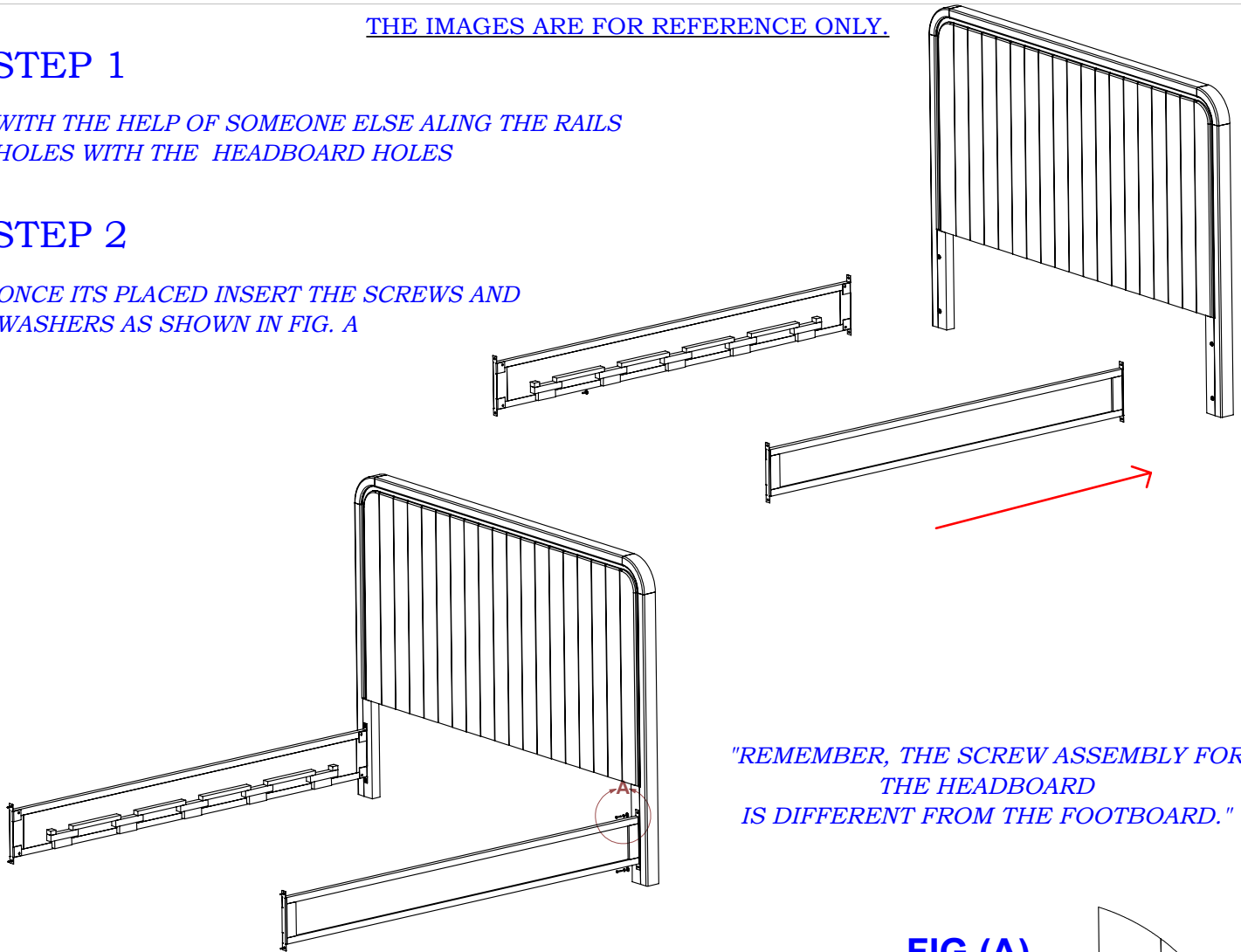

ASSEMBLING INSTRUCTIONS

I-PLT-E019

DESCRIPTION	#
SOCKET ALLEN BUTTON 5/16 X 1"	8
LOCK WASHER 5/16 "	8
FLAT WASHER 5/16 X 1"	8
ALLEN KEY 3/16	1

STEP 3

THE IMAGES ARE FOR REFERENCE ONLY.

NOW WITH THE HELP OF SOMEONE ELSE ALING THE RAILS HOLES WITH THE FOOTBOARD HOLES AND INSERT THE SCREWS AND WASHERS AS SHOWN IN [FIG. B]

SOCKET ALLEN BUTTON
HEAD 5/16 X 1"

LOCK WASHER 5/16
LOCK WASHER 5/16

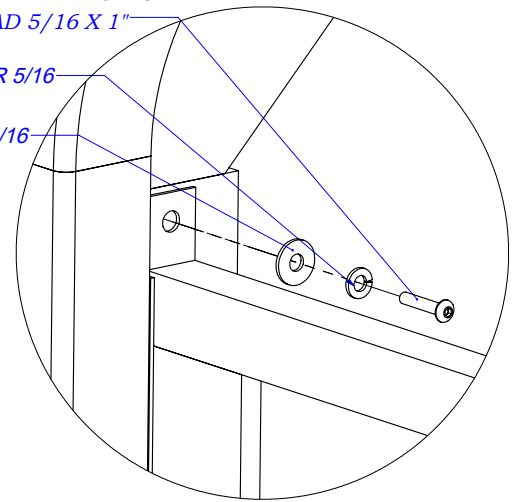
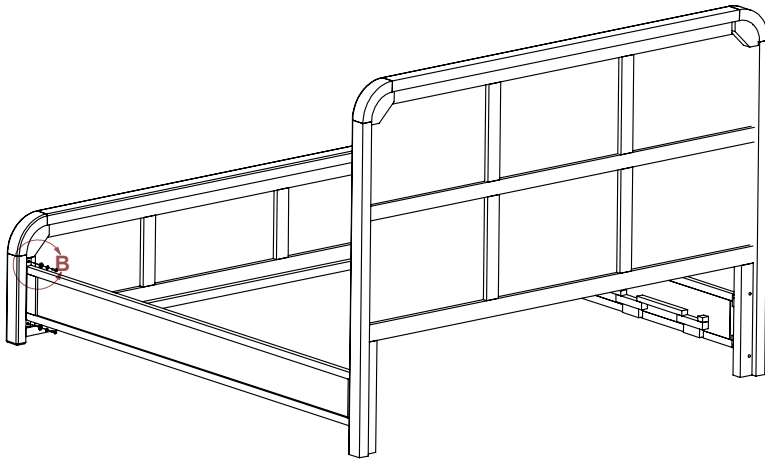

FIG (B)

"REMEMBER, THE SCREW ASSEMBLY FOR THE HEADBOARD IS DIFFERENT FROM THE FOOTBOARD."



STEP 4

FINALLY PLACE THE SLATS WITH THE LEGS IN THE BRACKETS OF THE RAILS AS SHOW IN THE (FIG C)

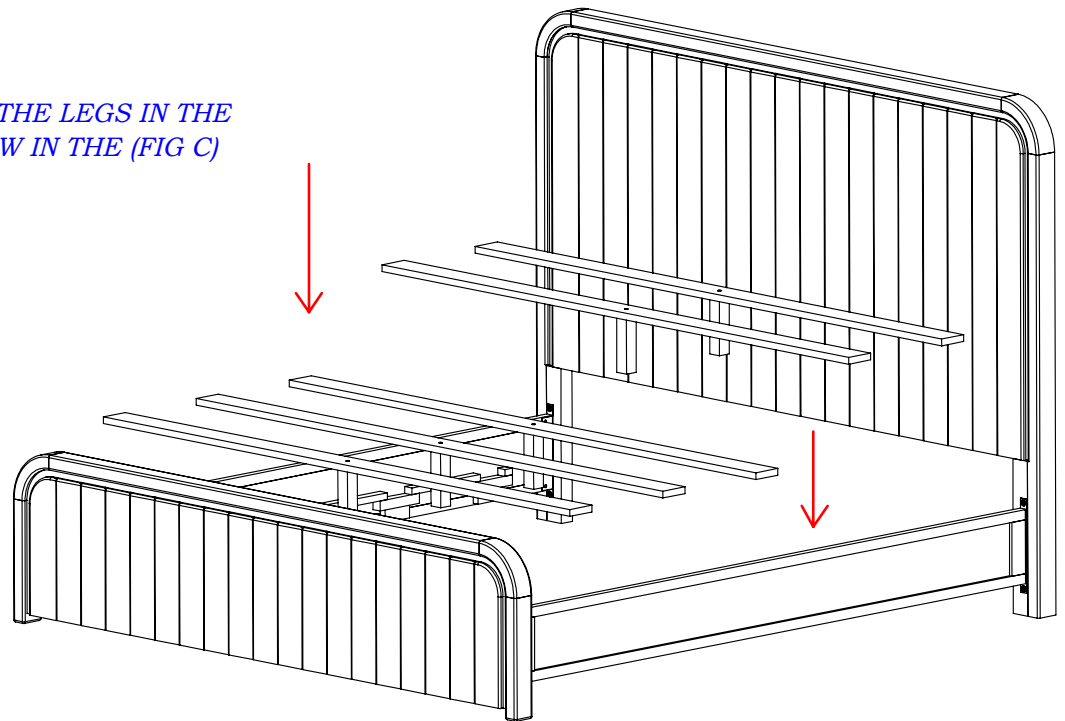

ASSEMBLING
INSTRUCTIONS

I-PLT-E019

DESCRIPTION	#
SOCKET ALLEN BUTTON 5/16 X 1"	8
LOCK WASHER 5/16 "	8
FLAT WASHER 5/16 X 1"	8
ALLEN KEY 3/16	1

ITEM	DESCRIPTION	#
1TOR008	TORNILLO ALLEN CAB. BOLA 5/16 X 1"	8
1RON011	RONDANA DE PRESION 5/16 "	8
1RON003	RONDANA PLANA 5/16 X 1"	8
1HER251	LLAVE ALLEN 3/16	1

RECUERDA QUE EL GANCHO NO LLEVA PARA COLOCAR PIJAS



ASSEMBLING
INSTRUCTIONS

I-PLT-E019